

Integrable Structures for 2D Euler Equations of Incompressible Inviscid Fluids

Yanguang (Charles) LI[†]

[†] *Department of Mathematics, University of Missouri, Columbia, MO 65211, USA*
E-mail: *cli@math.missouri.edu*

In this article, I will report a Lax pair structure, a Bäcklund-Darboux transformation, and the investigation of homoclinic structures for 2D Euler equations of incompressible inviscid fluids.

1 Introduction

The governing equation of turbulence, that we are interested in, is the incompressible 2D Navier-Stokes equation under periodic boundary conditions. We are particularly interested in investigating the dynamics of 2D Navier-Stokes equation in the infinite Reynolds number limit and of 2D Euler equation. Our approach is different from many other studies on 2D Navier-Stokes equation in which one starts with Stokes equation to prove results on 2D Navier-Stokes equation for small Reynolds number. In our studies, we start with 2D Euler equation and view 2D Navier-Stokes equation for large Reynolds number as a (singular) perturbation of 2D Euler equation. 2D Euler equation is a Hamiltonian system with infinitely many Casimirs. To understand the nature of turbulence, we start with investigating the hyperbolic structure of 2D Euler equation. We are especially interested in investigating the possible homoclinic structures.

In [1], we studied a linearized 2D Euler equation at a fixed point. The linear system decouples into infinitely many one-dimensional invariant subsystems. The essential spectrum of each invariant subsystem is a band of continuous spectrum on the imaginary axis. Only finitely many of these invariant subsystems have point spectra. The point spectra can be computed through continued fractions. Examples show that there are indeed eigenvalues with positive and negative real parts. Thus, there is linear hyperbolicity.

In [2] and [3], a Lax pair and a Bäcklund-Darboux transformation were found for the 2D Euler equation. Typically, Bäcklund-Darboux transformation can be used to generate homoclinic orbits [4].

The 2D Euler equation can be written in the vorticity form,

$$\partial_t \Omega + \{\Psi, \Omega\} = 0, \quad (1)$$

where the bracket $\{, \}$ is defined as

$$\{f, g\} = (\partial_x f)(\partial_y g) - (\partial_y f)(\partial_x g),$$

where Ψ is the stream function given by,

$$u = -\partial_y \Psi, \quad v = \partial_x \Psi,$$

u and v are the velocity components, and the relation between vorticity Ω and stream function Ψ is,

$$\Omega = \partial_x v - \partial_y u = \Delta \Psi.$$

2 A Lax Pair and a Darboux Transformation

Theorem 1 (Li, [2]). *The Lax pair of the 2D Euler equation (1) is given as*

$$\begin{cases} L\varphi = \lambda\varphi , \\ \partial_t\varphi + A\varphi = 0 , \end{cases} \quad (2)$$

where

$$L\varphi = \{\Omega, \varphi\} , \quad A\varphi = \{\Psi, \varphi\} ,$$

and λ is a complex constant, and φ is a complex-valued function.

Consider the Lax pair (2) at $\lambda = 0$, i.e.

$$\{\Omega, p\} = 0 , \quad (3)$$

$$\partial_t p + \{\Psi, p\} = 0 , \quad (4)$$

where we replaced the notation φ by p .

Theorem 2 (Li and Yurov, [3]). *Let $f = f(t, x, y)$ be any fixed solution to the system (3, 4), we define the Gauge transform G_f :*

$$\tilde{p} = G_f p = \frac{1}{\Omega_x} [p_x - (\partial_x \ln f)p] , \quad (5)$$

and the transforms of the potentials Ω and Ψ :

$$\tilde{\Psi} = \Psi + F , \quad \tilde{\Omega} = \Omega + \Delta F , \quad (6)$$

where F is subject to the constraints

$$\{\Omega, \Delta F\} = 0 , \quad \{\Omega + \Delta F, F\} = 0 . \quad (7)$$

Then \tilde{p} solves the system (3, 4) at $(\tilde{\Omega}, \tilde{\Psi})$. Thus (5) and (6) form the Darboux transformation for the 2D Euler equation (1) and its Lax pair (3, 4).

3 Preliminaries on Linearized 2D Euler Equation

We consider the two-dimensional incompressible Euler equation written in vorticity form(1) under periodic boundary conditions in both x and y directions with period 2π . We also require that both u and v have means zero,

$$\int_0^{2\pi} \int_0^{2\pi} u \, dx dy = \int_0^{2\pi} \int_0^{2\pi} v \, dx dy = 0.$$

We expand Ω into Fourier series,

$$\Omega = \sum_{k \in \mathbb{Z}^2 / \{0\}} \omega_k e^{ik \cdot X} ,$$

where $\omega_{-k} = \overline{\omega_k}$, $k = (k_1, k_2)^T$, $X = (x, y)^T$. In this paper, we confuse 0 with $(0, 0)^T$, the context will always make it clear. By the relation between vorticity Ω and stream function Ψ , the system (1) can be rewritten as the following kinetic system,

$$\dot{\omega}_k = \sum_{k=p+q} A(p, q) \omega_p \omega_q , \quad (8)$$

where $A(p, q)$ is given by,

$$A(p, q) = \frac{1}{2}[|q|^{-2} - |p|^{-2}](p_1 q_2 - p_2 q_1), \quad (9)$$

where $|q|^2 = q_1^2 + q_2^2$ for $q = (q_1, q_2)^T$, similarly for p .

We denote $\{\omega_k\}_{k \in Z^2/\{0\}}$ by ω . For any fixed $p \in Z^2/\{0\}$, we consider the simple fixed point ω^* :

$$\omega_p^* = \Gamma, \quad \omega_k^* = 0, \text{ if } k \neq p \text{ or } -p, \quad (10)$$

of the 2D Euler equation (8), where Γ is an arbitrary complex constant. The *linearized two-dimensional Euler equation* at ω^* is given by,

$$\dot{\omega}_k = A(p, k-p) \Gamma \omega_{k-p} + A(-p, k+p) \bar{\Gamma} \omega_{k+p}. \quad (11)$$

Definition 1 (Classes). For any $\hat{k} \in Z^2/\{0\}$, we define the class $\Sigma_{\hat{k}}$ to be the subset of $Z^2/\{0\}$:

$$\Sigma_{\hat{k}} = \left\{ \hat{k} + np \in Z^2/\{0\} \mid n \in Z, \text{ } p \text{ is specified in (10)} \right\}.$$

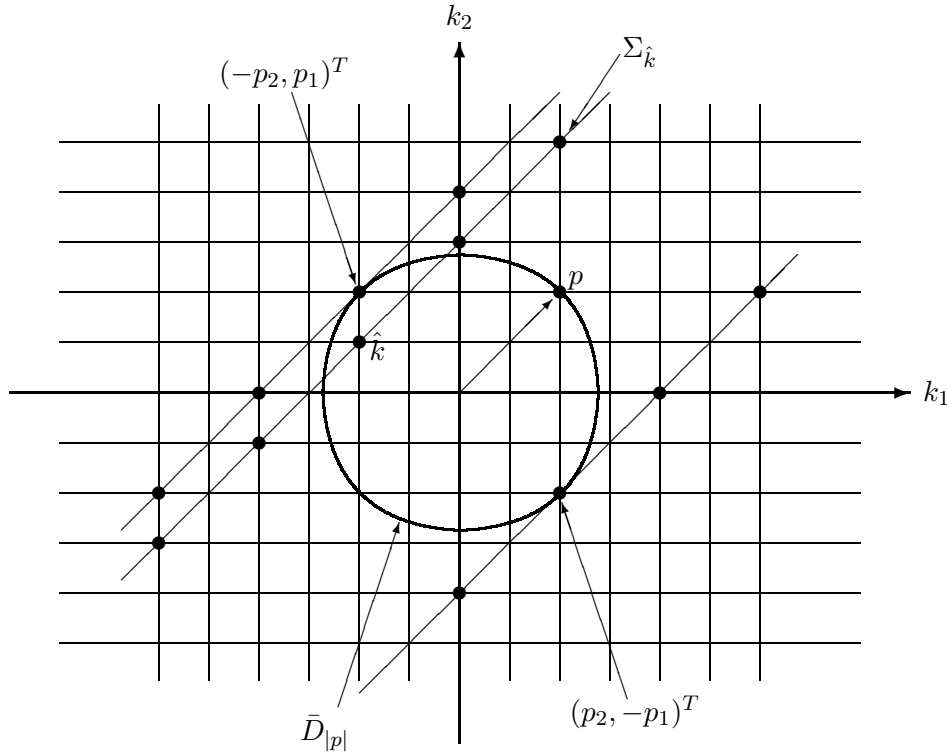

Figure 1. An illustration of the classes $\Sigma_{\hat{k}}$ and the disk $\bar{D}_{|p|}$.

See Figure 1 for an illustration. According to the classification defined in Definition 1, the linearized two-dimensional Euler equation (11) decouples into infinitely many *invariant subsystems*:

$$\begin{aligned} \dot{\omega}_{\hat{k}+np} &= A(p, \hat{k} + (n-1)p) \Gamma \omega_{\hat{k}+(n-1)p} \\ &+ A(-p, \hat{k} + (n+1)p) \bar{\Gamma} \omega_{\hat{k}+(n+1)p}. \end{aligned} \quad (12)$$

Theorem 3. *The eigenvalues of the linear operator $\mathcal{L}_{\hat{k}}$ defined by the right hand side of (12), are of four types: real pairs $(c, -c)$, purely imaginary pairs $(id, -id)$, quadruples $(\pm c \pm id)$, and zero eigenvalues.*

The eigenvalues can be computed through continued fractions.

Definition 2 (The Disk). The disk of radius $|p|$ in $Z^2/\{0\}$, denoted by $\bar{D}_{|p|}$, is defined as

$$\bar{D}_{|p|} = \left\{ k \in Z^2/\{0\} \mid |k| \leq |p| \right\}.$$

Theorem 4 (The Spectral Theorem). *We have the following claims on the spectra of the linear operator $\mathcal{L}_{\hat{k}}$:*

1. *If $\Sigma_{\hat{k}} \cap \bar{D}_{|p|} = \emptyset$, then the entire ℓ_2 spectrum of the linear operator $\mathcal{L}_{\hat{k}}$ is its continuous spectrum. See Figure 2, where $b = -\frac{1}{2}|\Gamma||p|^{-2} \begin{vmatrix} p_1 & \hat{k}_1 \\ p_2 & \hat{k}_2 \end{vmatrix}$.*
2. *If $\Sigma_{\hat{k}} \cap \bar{D}_{|p|} \neq \emptyset$, then the entire essential ℓ_2 spectrum of the linear operator $\mathcal{L}_{\hat{k}}$ is its continuous spectrum. That is, the residual spectrum of $\mathcal{L}_{\hat{k}}$ is empty, $\sigma_r(\mathcal{L}_{\hat{k}}) = \emptyset$. The point spectrum of $\mathcal{L}_{\hat{k}}$ is symmetric with respect to both real and imaginary axes. See Figure 2.*

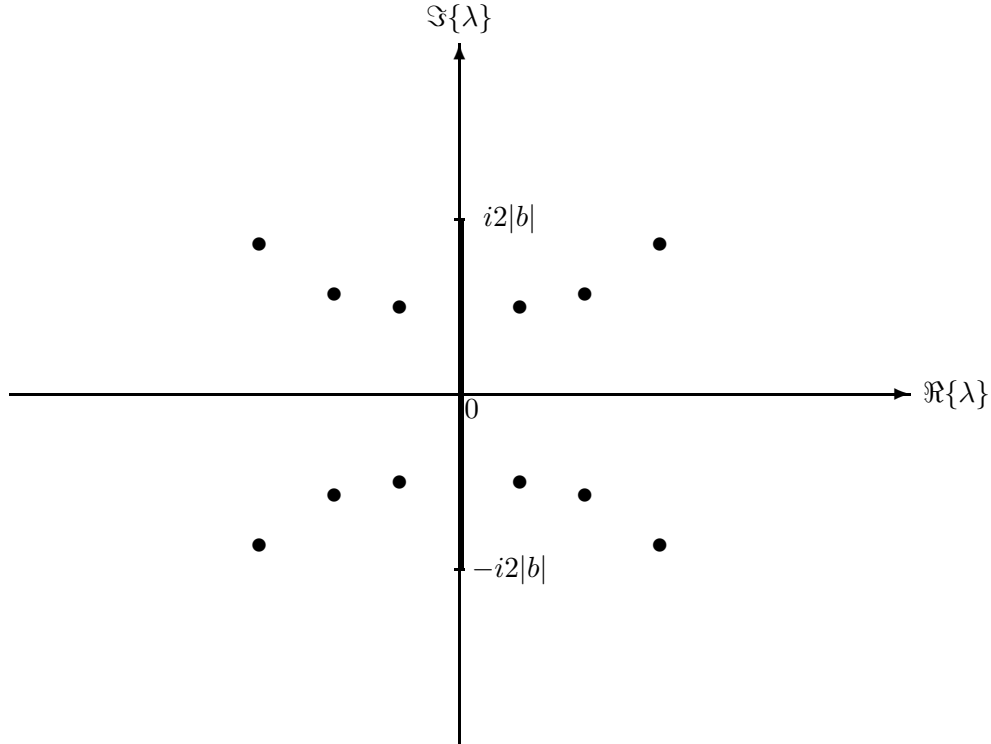

Figure 2. The spectrum of $\mathcal{L}_{\hat{k}}$.

4 A Galerkin Truncation

To simplify our study, we study only the case when ω_k is real, $\forall k \in Z^2/\{0\}$, i.e. we only study the cosine transform of the vorticity,

$$\Omega = \sum_{k \in Z^2/\{0\}} \omega_k \cos(k \cdot X),$$

and the 2D Euler equation (1;8) preserves the cosine transform. To further simplify our study, we will study a concrete line of fixed points (10) with the mode $p = (1, 1)^T$ parametrized by Γ . When $\Gamma \neq 0$, each fixed point has 4 eigenvalues which form a quadruple. These four eigenvalues appear in the only unstable invariant linear subsystem labeled by $\hat{k} = (-3, -2)^T$. See Figure 3 for an illustration. We computed the eigenvalues through continued fractions, one of them is

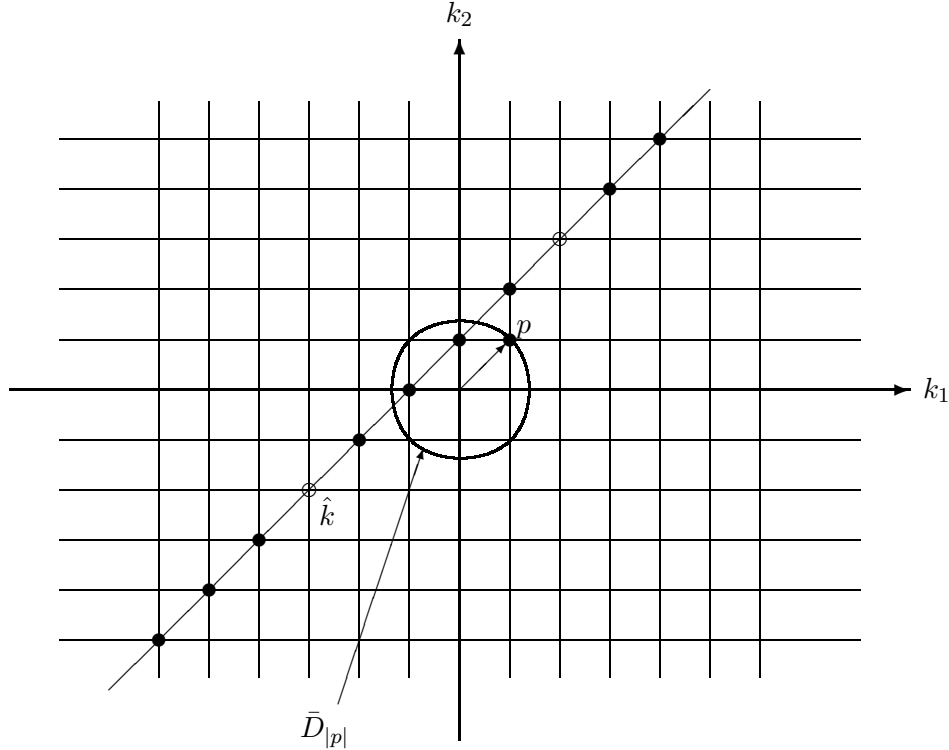

Figure 3. The collocation of the modes in the Galerkin truncation.

[1]:

$$\tilde{\lambda} = 2\lambda/|\Gamma| = 0.24822302478255 + i 0.35172076526520 . \quad (13)$$

We hope that a Galerkin truncation with a small number of modes including those inside the disk $\bar{D}_{|p|}$ can capture the eigenvalues. We propose the Galerkin truncation to the linear system (12) with the four modes $\hat{k} + p$, $\hat{k} + 2p$, $\hat{k} + 3p$, and $\hat{k} + 4p$,

$$\begin{aligned} \dot{\omega}_1 &= -A_2\Gamma\omega_2, \\ \dot{\omega}_2 &= A_1\Gamma\omega_1 - A_3\Gamma\omega_3, \\ \dot{\omega}_3 &= A_2\Gamma\omega_2 - A_4\Gamma\omega_4, \\ \dot{\omega}_4 &= A_3\Gamma\omega_3. \end{aligned}$$

From now on, the abbreviated notations,

$$\omega_n = \omega_{\hat{k}+np}, \quad A_n = A(p, \hat{k} + np), \quad A_{m,n} = A(\hat{k} + mp, \hat{k} + np), \quad (14)$$

will be used. The eigenvalues of this four dimensional system can be easily calculated. It turns out that this system has a quadruple of eigenvalues:

$$\lambda = \pm \frac{\Gamma}{2\sqrt{10}} \sqrt{1 \pm i\sqrt{35}} \doteq \pm \left(\frac{\Gamma}{2}\right) \times 0.7746 \times e^{\pm i\theta_1}, \quad (15)$$

where $\theta_1 = \arctan(0.845)$, in comparison with the quadruple of eigenvalues (13), where

$$\lambda \doteq \pm \left(\frac{\Gamma}{2} \right) \times 0.43 \times e^{\pm i\theta_2},$$

and $\theta_2 = \arctan(1.418)$. Thus, *the quadruple of eigenvalues of the original system is recovered by the four-mode truncation.* We further study the corresponding Galerkin truncation of 2D Euler equation:

$$\begin{aligned} \dot{\omega}_1 &= -A_2 \omega_p \omega_2, \\ \dot{\omega}_2 &= A_1 \omega_p \omega_1 - A_2 \omega_p \omega_3, \\ \dot{\omega}_3 &= A_2 \omega_p \omega_2 - A_1 \omega_p \omega_4, \\ \dot{\omega}_4 &= A_2 \omega_p \omega_3, \\ \dot{\omega}_p &= A_{1,2} (\omega_3 \omega_4 - \omega_1 \omega_2), \end{aligned} \tag{16}$$

and the equations for the decoupled variables ω_0 and ω_5 are given by,

$$\begin{aligned} \dot{\omega}_0 &= -A_1 \omega_p \omega_1, \\ \dot{\omega}_5 &= A_1 \omega_p \omega_4. \end{aligned}$$

where

$$\begin{aligned} A_1 &= -\frac{3}{10}, \quad A_2 = \frac{1}{2}, \quad A_3 = A_2, \quad A_4 = A_1, \\ A_{1,2} &= A_1 - A_2 = -\frac{4}{5}, \quad A_{2,3} = 0, \quad A_{3,4} = -A_{1,2}; \end{aligned}$$

There are three invariants for the system (16):

$$I = 2A_{1,2}(\omega_1\omega_3 + \omega_2\omega_4) + A_2\omega_p^2, \tag{17}$$

$$U = A_1(\omega_1^2 + \omega_4^2) + A_2(\omega_2^2 + \omega_3^2), \tag{18}$$

$$J = \omega_p^2 + \omega_1^2 + \omega_2^2 + \omega_3^2 + \omega_4^2. \tag{19}$$

J is the enstrophy, and U is a linear combination of the kinetic energy and the enstrophy. I is an extra invariant which is peculiar to this invariant subsystem. With I , the explicit formula for the hyperbolic structure can be computed.

The common level set of these three invariants which is connected to the fixed point (10) determines the stable and unstable manifolds of the fixed point and its negative $-\omega^*$:

$$\omega_p = -\Gamma, \quad \omega_n = 0 \quad (n \in Z). \tag{20}$$

Using the polar coordinates:

$$\omega_1 = r \cos \theta, \quad \omega_4 = r \sin \theta; \quad \omega_2 = \rho \cos \vartheta, \quad \omega_3 = \rho \sin \vartheta;$$

we have the following explicit expressions for the stable and unstable manifolds of the fixed point (10) and its negative (20) represented through the homoclinic orbits asymptotic to the line of

fixed points:

$$\begin{aligned}
\omega_p &= \Gamma \tanh \tau, \\
r &= \sqrt{\frac{A_2}{A_2 - A_1}} \Gamma \operatorname{sech} \tau, \\
\theta &= -\frac{A_2}{2\kappa} \ln \cosh \tau + \theta_0, \\
\rho &= \sqrt{\frac{-A_1}{A_2}} r, \\
\theta + \vartheta &= \begin{cases} -\arcsin \left[\frac{1}{2} \sqrt{\frac{A_2}{-A_1}} \right], & (\kappa > 0), \\ \pi + \arcsin \left[\frac{1}{2} \sqrt{\frac{A_2}{-A_1}} \right], & (\kappa < 0), \end{cases}
\end{aligned} \tag{21}$$

where A_1 and A_2 are given in (16), $\tau = \kappa\Gamma t + \tau_0$, (τ_0, θ_0) are the two parameters parametrizing the two-dimensional stable (unstable) manifold, and

$$\kappa = \sqrt{-A_1 A_2} \cos(\theta + \vartheta) = \pm \sqrt{-A_1 A_2} \sqrt{1 + \frac{A_2}{4A_1}}.$$

The two auxiliary variables ω_0 and ω_5 have the expressions:

$$\begin{aligned}
\omega_0 &= \frac{\alpha\beta}{1 + \beta^2} \operatorname{sech} \tau \left\{ \sin[\beta \ln \cosh \tau + \theta_0] - \frac{1}{\beta} \cos[\beta \ln \cosh \tau + \theta_0] \right\}, \\
\omega_5 &= \frac{\alpha\beta}{1 + \beta^2} \operatorname{sech} \tau \left\{ \cos[\beta \ln \cosh \tau + \theta_0] + \frac{1}{\beta} \sin[\beta \ln \cosh \tau + \theta_0] \right\},
\end{aligned}$$

where

$$\alpha = -A_1 \Gamma \kappa^{-1} \sqrt{\frac{A_2}{A_2 - A_1}}, \quad \beta = -\frac{A_2}{2\kappa}.$$

The graphs of these homoclinic orbits are spirals on a 2D ellipsoid, with turning points.

5 Conclusion

Certain newly developed results on 2D Euler equation have been discussed, which include a Lax pair, a Darboux transformation, and the investigation on homoclinic structures.

- [1] Y. Li, *On 2D Euler equations: Part I. On the energy-Casimir stabilities and the spectra for linearized 2D Euler equations*, J. Math. Phys., 41, No.2, pp. 728–758, (2000).
- [2] Y. Li, *A Lax pair for the two dimensional Euler equation*, J. Math. Phys., 42, No.8, (2001).
- [3] Y. Li and A. Yurov, *Lax pairs and Darboux transformations for Euler equations*, Submitted, (2001).
- [4] Y. Li, *Bäcklund-Darboux transformations and Melnikov analysis for Davey-Stewartson II equations*, J. Nonlinear Sci. **10** 2000, pp. 103–131.
- [5] Y. Li, *On 2D Euler equations: Part II. Lax pairs and homoclinic structures*, Submitted, (2001).